

NEW

TRW 1305 HS

This transfer has been specifically developed for use with high speed production lines. Max speed 500 bottle per minute.

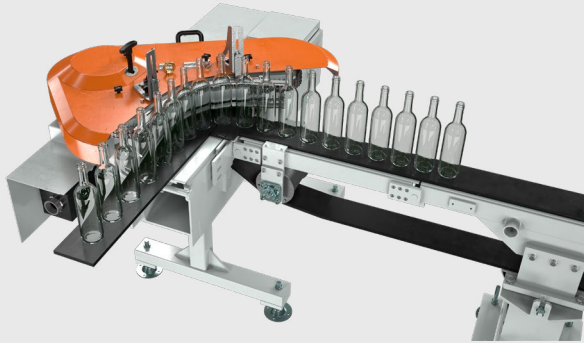

FEATURES & BENEFITS

- Precise retraction of pushing fingers on the output side of the transfer wheel
- Adjustable top and bottom ware guide
- Operate with 150, 175, 200 and 250mm wide delivery belts
- Small width of the transfer plate (120 mm)
- Chain: pitch 3/4", length 90" (120 links), double row with extended pins
- Chain tension system
- Phase/emergency clutch
- Quick change finger & different finger size

NEW

TRW HSS DOUBLE CHAIN

Ware transfer system specially developed for handling containers on TG and QG production machine with high speed production lines. Max speed 900 bottle per minute.

FEATURES

- Double belt conveyor drive and transfer wheel with large transferring radius
- Short conveyor belt speed can be regulated independently
- Precise retraction pushing finger on the input and the output side of transfer wheel
- Adjustable top ware guide (in-out & up-down) and bottom wareguide (in-out regulation)
- Chain: pitch 3/4", length 157.5" (210 links), double row with extended pins
- Electronic timer and clutch handling
- Phase and emergency clutch
- Quick change finger
- Optimize lubrication system

Standard conveyor belt configuration: 6" wide is conveyor belt + 8" wide short conveyor belt.

BENEFITS

- Smooth and accurate container positioning to the cross-conveyor belt due to special finger motion system
- Short conveyor belt ensure that container are in steady contact with finger during transfer

